

ModularEasy

9PXMEZ6Ki
9PXMEZ11Ki

Installation
and user manual

Copyright © 2013 **EATON**
All rights reserved.

Service and support:
Call your local service representative

614-09354-00_EN

SAFETY INSTRUCTIONS

SAVE THESE INSTRUCTIONS. This manual contains important instructions that should be followed during installation and maintenance of the ModularEasy and UPS.

The ModularEasy models that are covered in this manual are intended for installation in an environment within 0 to 40°C, free of conductive contaminant.

These limits are designed to provide reasonable protection against harmful interference when the equipment is operated in a commercial environment. This equipment generates, uses, and can radiate radio frequency energy and, if not installed and used in accordance with the instruction manual, may cause harmful interference to radio communications. Operation of this equipment in a residential area is likely to cause harmful interference in which case the user will be required to correct the interference at his own expense.

Certification standards (in use with UPS)

- Safety: IEC/EN 62040-1 / Ed.1: 2008.
- EMC: IEC/EN 62040-2 / Ed.2: 2006.
- Performance: IEC/EN 62040-3 / Ed.2.0: 2011.
- IEC 61000-4-2 (ESD): level 3.
- IEC 61000-4-3 (Radiated field): level 3.
- IEC 61000-4-4 (EFT): level 4.
- IEC 61000-4-5 (Fast transients): level 4.
- IEC 61000-4-6 (Electromagnetic field): level 3.
- IEC 61000-4-8 (Conducted magnetic field): level 4.

Special symbols

The following are examples of symbols used on the ModularEasy to alert you to important information:



RISK OF ELECTRIC SHOCK - Observe the warning associated with the risk of electric shock symbol.



Important instructions that must always be followed.



This symbol indicates that you should not discard waste electrical or electronic equipment (WEEE) in the trash. For proper disposal, contact your local recycling/reuse or hazardous waste center.



Information, advice, help.

Safety of persons

- The system has its own power source when connected to the UPS (UPS battery). Consequently, the power outlets may be energized even if the system is disconnected from the AC power source. Dangerous voltage levels are present within the system. It should be opened exclusively by qualified service personnel.
- The product must be properly grounded, always connect the earth wire first

Product safety

- The ModularEasy connection instructions and operation described in the manual must be followed in the indicated order. Disconnection and overcurrent protection devices shall be provided by others for AC in/out circuits.
- CAUTION -To reduce the risk of fire, the unit connects only to a circuit provided with branch circuit overcurrent protection (please refer to the UPS User Manual for current rating). The upstream circuit breaker must be easily accessible. The unit can be disconnected from AC power source by opening this circuit breaker, and if still connected to UPS, by previously shutting down the UPS (refer to the UPS User Manual)
- Check that the indications on the rating plate correspond to your AC powered system and to the actual electrical consumption of all the equipment to be connected to the system.
- For PLUGGABLE EQUIPMENT, the socket-outlet shall be installed near the equipment and shall be easily accessible
- Never install the system near liquids or in an excessively damp environment.
- Never let a foreign body penetrate inside the system.
- Never expose the system to direct sunlight or source of heat.
- If the system must be stored prior to installation, storage must be in a dry place.
- The admissible storage temperature range is -15°C to +60°C.

Special precautions

- The ModularEasy is designed to work with approved EATON UPS (contact your Eaton reseller for more information).
- All repairs and service should be performed by AUTHORIZED SERVICE PERSONNEL ONLY.
- There are NO USER SERVICEABLE PARTS inside the ModularEasy.

Contents

1. Introduction	5
1.1 Environmental protection	5
2. Presentation	6
2.1 Standard installation	6
2.2 Description / Panels	7
2.3 Firmware upgrade	8
2.4 Parallel UPS screen	8
2.5 Parallel setting	8
3. Installation	9
3.1 Inspecting the equipment	9
3.2 Unpacking the ModularEasy	9
3.3 Checking the accessory kit	9
3.4 Tower installation	10
3.5 Rack installation with non-included optional Rail Kit: 9RK	10
3.6 Example of rack 19" setup with optional EBM 9PX EBM 240V	11
3.7 Example of battery integration system with non-included optional Trolley Frame: BINTSYS	11
3.8 Installation requirements	12
4. Power cables connection	14
4.1 9PXMEZ6Ki	14
4.2 9PXMEZ11Ki - with common Normal and Bypass AC source	16
4.3 9PXMEZ11Ki - with separate Normal and Bypass AC source	18
5. Operations	20
5.1 UPS parallel system start-up	20
5.2 UPS maintenance with ModularEasy	21
5.3 UPS replacement with ModularEasy	22
6. Troubleshooting	24
7. Specifications	24

Thank you for selecting an EATON product to protect your electrical equipment.

The ModularEasy range has been designed with the utmost care.

We recommend that you take the time to read this manual to take full advantage of the many features of your ModularEasy.

Before installing your ModularEasy with your UPS, please read first the safety instructions. Then follow the indications in this manual, which completes the UPS Installation and User Manual.

To discover the entire range of EATON products, we invite you to visit our web site at www.eaton.com/powerquality or contact your EATON representative.

1.1 Environmental protection

EATON has implemented an environmental-protection policy. Products are developed according to an eco-design approach.

Substances

This product does not contain CFCs, HCFCs or asbestos.

Packing

To improve waste treatment and facilitate recycling, separate the various packing components.

- The cardboard we use comprises over 50% of recycled cardboard.
- Sacks and bags are made of polyethylene.
- Packing materials are recyclable and bear the appropriate identification symbol



Materials	Abbreviations	Number in the symbols	
Polyethylene terephthalat	PET	01	
High-density polyethylene	HDPE	02	
Polyvinyl chloride	PVC	03	
Low-density polyethylene	LDPE	04	
Polypropylene	PP	05	
Polystyrene	PS	06	

Follow all local regulations for the disposal of packing materials.

End of life



EATON will process products at the end of their service life in compliance with local regulations. EATON works with companies in charge of collecting and eliminating our products at the end of their service life.

Product



The product is made up of recyclable materials. Dismantling and destruction must take place in compliance with all local regulations concerning waste. At the end of its service life, the product must be transported to a processing center for electrical and electronic waste.

2. Presentation

The Eaton® ModularEasy is an essential part of your Parallel system. It allows the connection of 2 UPS together, moreover, it possible to service or even replace the UPS without affecting the connected loads.

You can safely eliminate the effects of UPS maintenance and guard the integrity of your equipment. Providing outstanding reliability, the Eaton ModularEasy unique benefits include:

- easy and fast connection to UPS due to Input/Output and signal "all in one" patented connector (ModularEasy 5/6kVA range)
- **"make before break"** feature to allow full servicing (electrical power continuity) when switching from UPS position to Bypass (and vice versa)
- communication feature with UPS: detection of ModularEasy connection and switch position (Normal or Bypass)
- load connection by both terminal blocks and IEC outlets (16A C19).

2.1 Standard installation

Rack installation

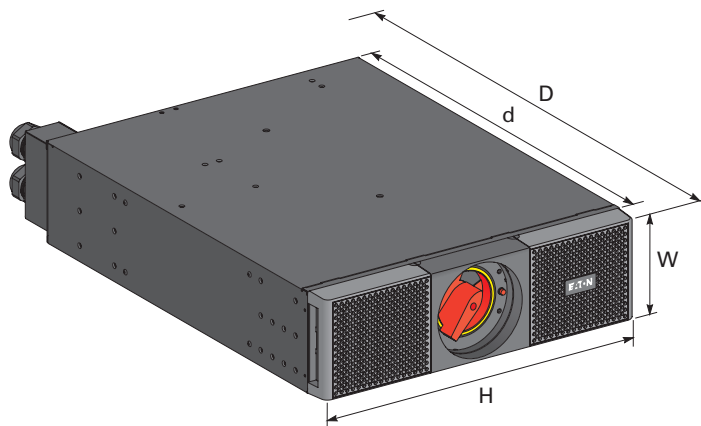

Tower installation

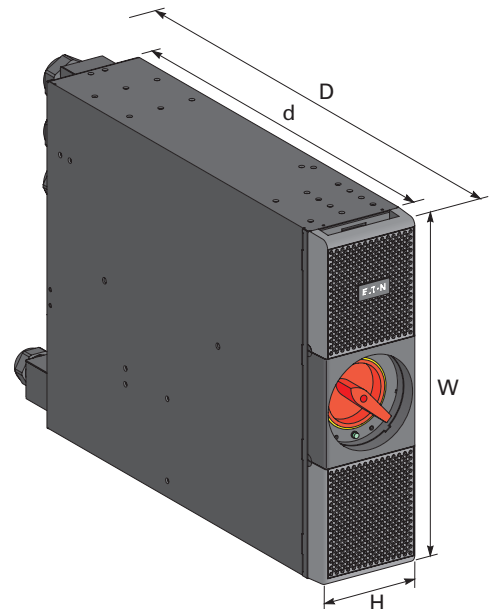

Description	Weight (lb/kg)	Overall Dimensions (inch/mm) D x W x H	Rack Dimensions (inch/mm) d x W x H
9PXMEZ6Ki	22.8 / 10.3	27 x 17 x 5 / 690 x 440 x 130	21.3 x 17 x 5 / 540 x 440 x 130
9PXMEZ11Ki	32.6 / 15	27 x 17 x 5 / 690 x 440 x 130	21.3 x 17 x 5 / 540 x 440 / 130

2.2 Description / Panels

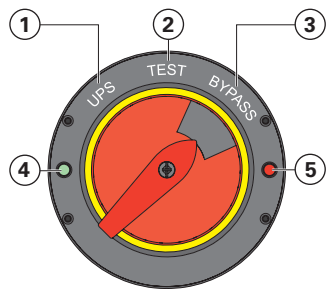

The ModularEasy has a manual Bypass rotary switch with three positions:

- ① **UPS:** the load is supplied by the UPS.
- ② **Test:** the load is supplied directly by the AC power source, **the two UPS are still supplied but their outputs are disconnected from the load.**
- ③ **Bypass:** the load is supplied directly by the AC power source, **the two UPS are disconnected from the AC power source.**

Lights indicate the ModularEasy power status:

- ④ **"UPS supply" green light** is active when at least one UPS output is available.
- ⑤ **"Bypass mode" red light** is active when the manual Bypass switch of the ModularEasy is on TEST or BYPASS position. **The load is not protected.**



On 9PXMEZ11Ki, it is possible to Bypass the load on a separate Bypass AC source (see "4.3 9PXMEZ11Ki - with separate Normal and Bypass AC source", page 18 for more details).

9PXMEZ6Ki

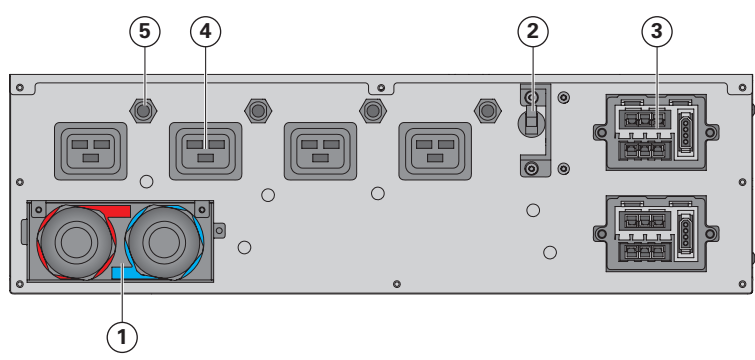

- ① Input/Output terminal blocks
- ② UPS output switch
- ③ Input/Output cables for connection to UPS1 and UPS2
- ④ 16A outlets
- ⑤ Outlets circuit breaker
- ⑥ "Bypass" source input UPS1 and UPS2
- ⑦ Signal cable for 9PXMEZ detection to the UPS

9PXMEZ11Ki

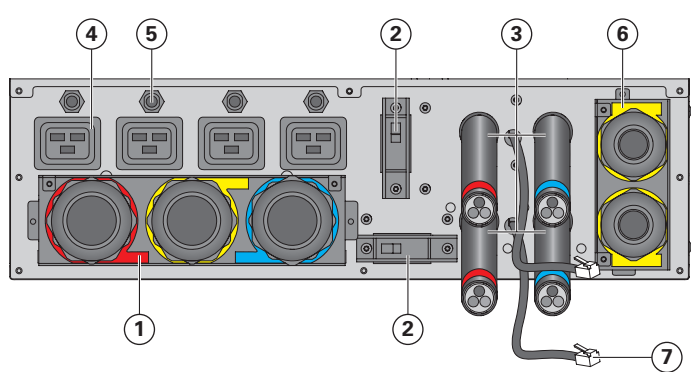

UPS output switch ② allows to disconnect the output power of the UPS, for UPS maintenance / replacing. See "5. Operations", page 20.

ModularEasy status detection ⑦ :

A RJ11 signal cable allows to display the following statuses on the UPS display panel:

- ModularEasy connection to UPS
- Bypass switch position.

2. Presentation

2.3 Firmware upgrade



Check that UPS firmware version is parallel compatible:
Screen menu → Identification → UPS/NMC firmware.

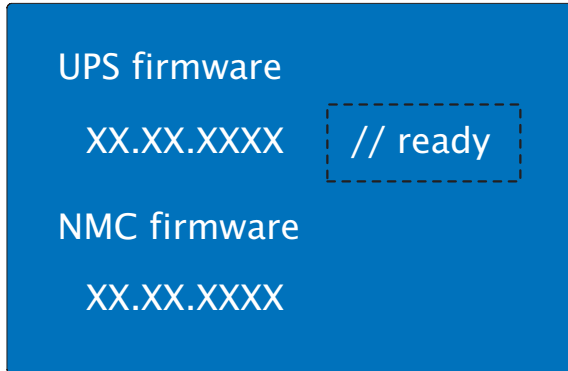

If "**// Ready**" doesn't appear just next to the UPS firmware number, that means the UPS cannot be connected in parallel.

Contact your Eaton reseller to download the latest firmware.

2.4 Parallel UPS screen

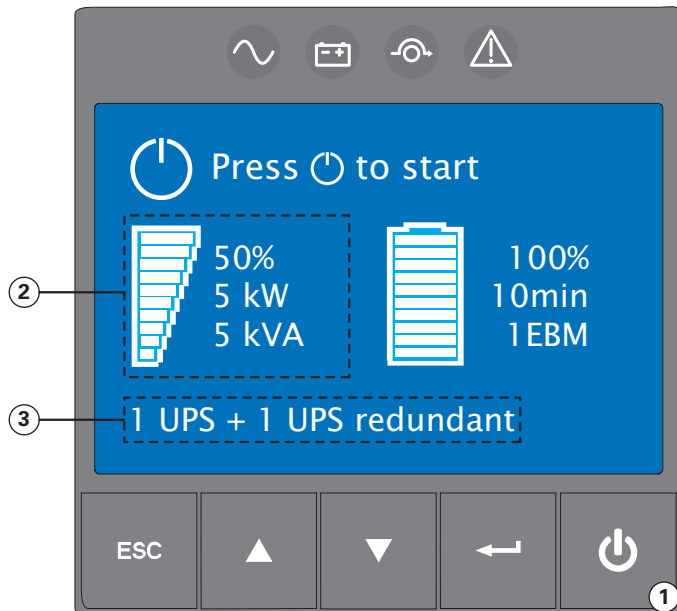

- ① Press [power button] of any one of the two UPS to start the parallel system.
- ② The Power display is the UPS power and not the load power. The load power is the sum of UPS1 power display + UPS2 power display
- ③ "**1 UPS + 1 UPS redundant**" means the load power is less than the maximum power of one UPS.
"2 UPS + 0 UPS redundant" means the load power is more than the maximum power of one UPS.
"1 UPS + 0 UPS redundant" means only one UPS powers the load.

2.5 Parallel setting

Press the Enter (←) button to activate the menu options.

Main menu	Submenu	Available settings	
Settings	In/Out settings	Redundancy mode	[Parallel Operation]
			[Redundancy Only]

[Parallel Operation]: set this mode to cancel the audible alarm when the load power is more than the maximum power of one UPS: "Parallel Operation" is the default mode.

[Redundancy Only]: set this mode to have an audible alarm when the load power is more than the maximum power of one UPS.

3.1 Inspecting the equipment

If any equipment has been damaged during shipment, keep the shipping cartons and packing materials for the carrier or place of purchase and file a claim for shipping damage. If you discover damage after acceptance, file a claim for concealed damage.

To file a claim for shipping damage or concealed damage:

1. File with the carrier within 15 days of receipt of the equipment;
2. Send a copy of the damage claim within 15 days to your service representative.

3.2 Unpacking the ModularEasy

Unpack the equipment and remove all the packing materials and shipping carton.

Discard or recycle the packaging in a responsible manner, or store it for future use.

Place the cabinet in a protected area that has adequate airflow and is free of humidity, flammable gas, and corrosion.



Packing materials must be disposed of in compliance with all local regulations concerning waste. Recycling symbols are printed on the packing materials to facilitate sorting.

3.3 Checking the accessory kit

- Verify that the following additional items are included with the ModularEasy:

9PXMEZ6Ki

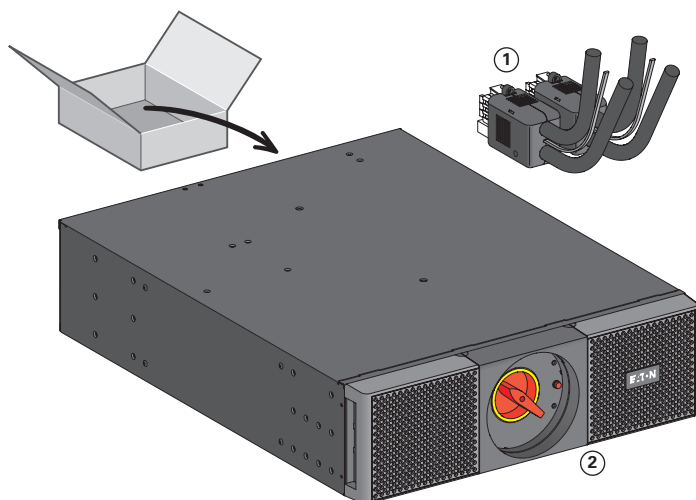

- ① Input/Output UPS cord Set
- ② ModularEasy chassis
- ③ 9PX Parallel cable PN: 744-65422-01
- ④ Tower and Wall mounting kit (including 4 ears and screws)
- ⑤ Installation and User manual

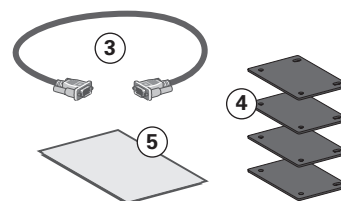

9PXMEZ11Ki

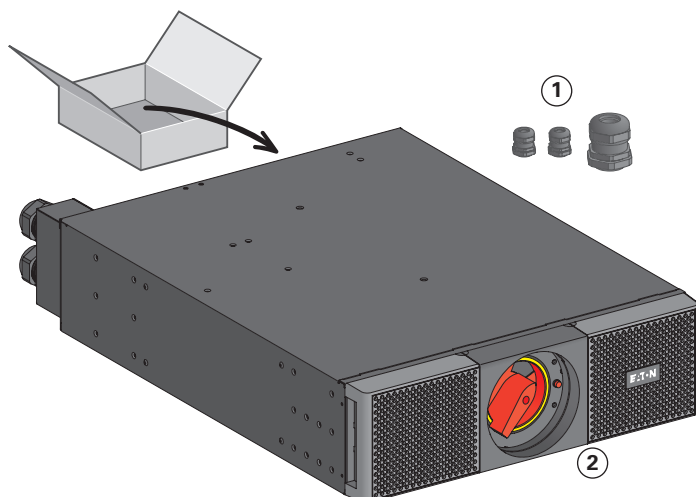

- ① Cable Gland
- ② ModularEasy chassis
- ③ 9PX Parallel cable PN: 744-65422-01
- ④ Tower and Wall mounting kit (including 4 ears and screws)
- ⑤ Installation and User manual

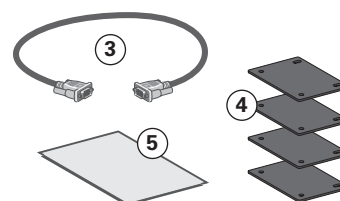

3. Installation

3.4 Tower installation

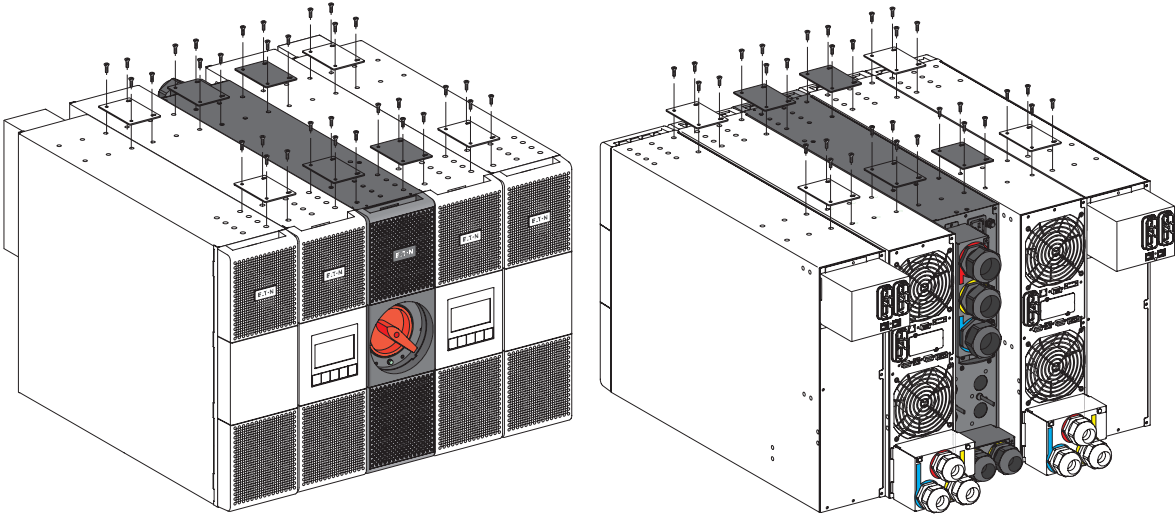

3.5 Rack installation with non-included optional Rail Kit: 9RK

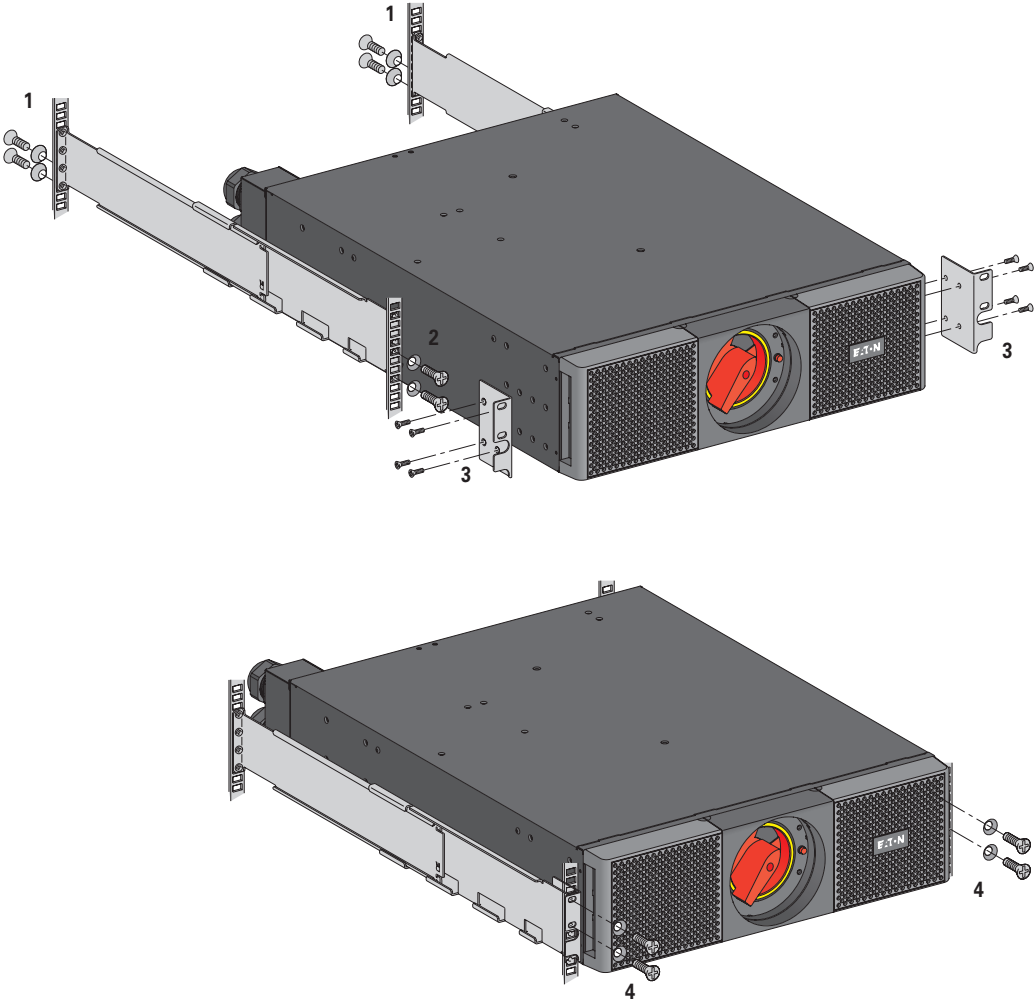

3.6 Example of rack 19" setup with optional EBM 9PX EBM 240V

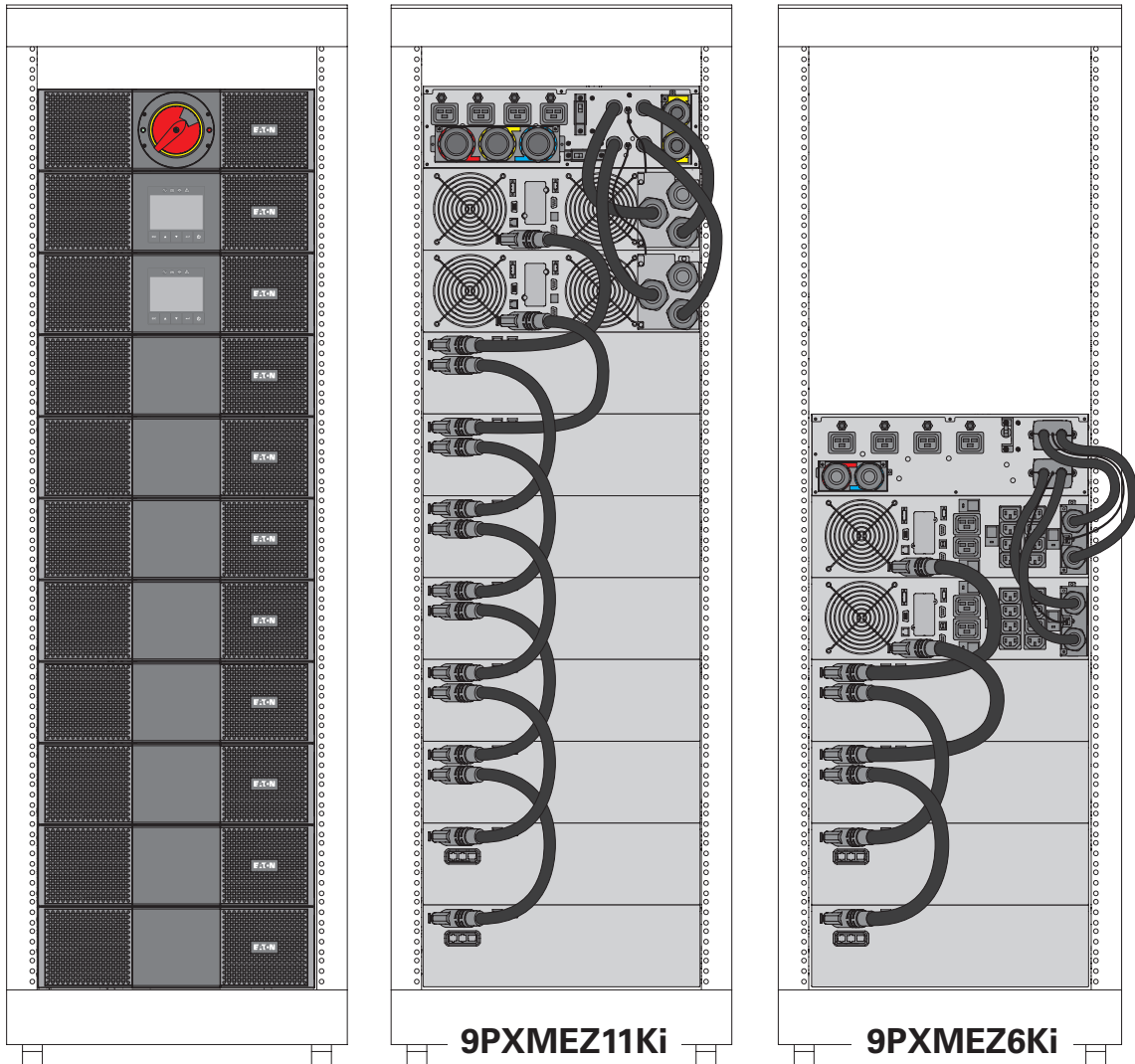

3.7 Example of battery integration system with non-included optional Trolley Frame: BINTSYS

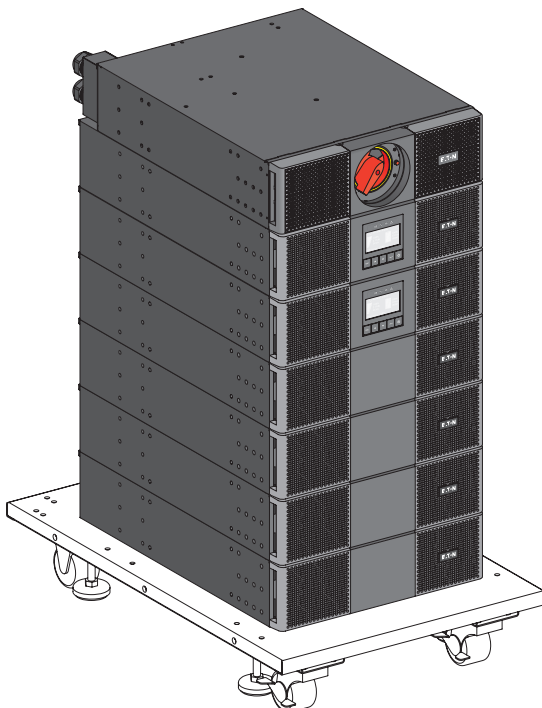

3. Installation

3.8 Installation requirements

Recommended protective devices and cable cross-sections

3.8.1 9PXMEZ6Ki use with 9PX6000 or 9PX5000 UPS

- Recommended protective devices

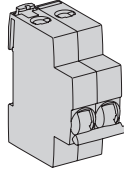

D curve, 63A for Parallel Operation

D curve, 32A for Redundancy Only

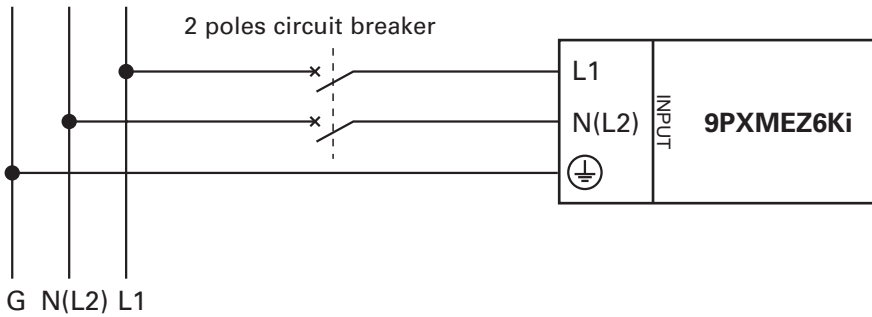

- Recommended cable cross-sections:

	Terminal position	Wire function	Terminal wire size rating	Minimum input wire size rating	Breaker D Curve
9PXMEZ6Ki Parallel Operation	L1	Phase	4-25 mm ² (12-4 AWG)	10 mm ² (8 AWG)	63A
	N (L2)	Neutral (Phase)			
	⊕	Ground			
9PXMEZ6Ki Redundancy Only	L1	Phase	4-25 mm ² (12-4 AWG)	6 mm ² (10 AWG)	32A
	N (L2)	Neutral (Phase)			
	⊕	Ground			

3.8.2 9PXMEZ11Ki use with 9PX8000 or 9PX11000 UPS

- Common input source recommended protective devices

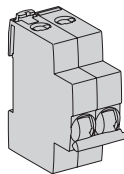

For Parallel Operation

D curve, 125A if use with 9PX11000 UPS

D curve, 100A if use with 9PX8000 UPS

For Redundancy Only

D curve, 63A if use with 9PX11000 UPS

D curve, 50A if use with 9PX8000 UPS

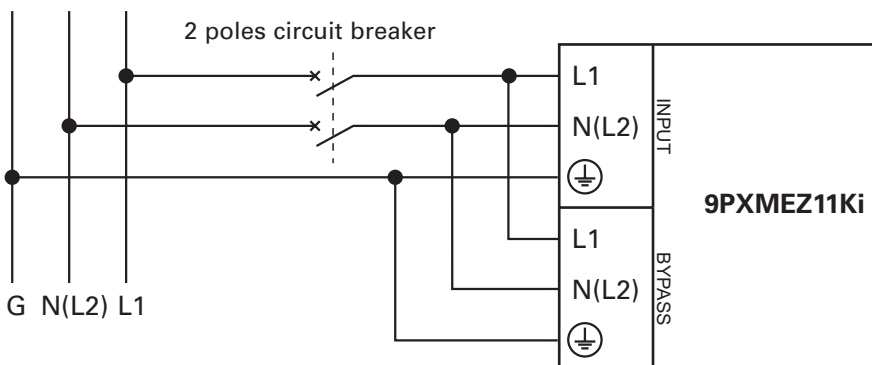

3.8 Installation requirements

Recommended protective devices and cable cross-sections

3.8.3 9PXMEZ11Ki use with 9PX8000 or 9PX11000 UPS

- Separate input source recommended protective devices

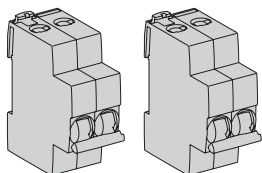

For Parallel Operation
 D curve, 125A if use with 9PX11000 UPS
 D curve, 100A if use with 9PX8000 UPS
 For Redundancy Only
 D curve, 63A if use with 9PX11000 UPS
 D curve, 50A if use with 9PX8000 UPS

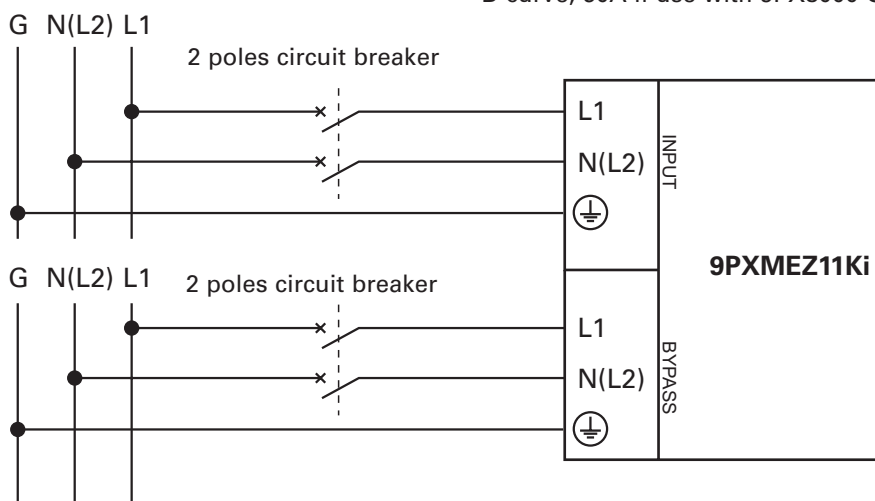

- Recommended cable cross-sections:

9PXMEZ11Ki	Normal AC source and Bypass AC source				
	Terminal position	Wire function	Terminal wire size rating	Minimum input wire size rating	Breaker D Curve
Parallel Operation with 9PX11000 UPS	L1	Phase	4-35 mm ² (12-4 AWG)	35 mm ² (1 AWG)	125A
	N (L2)	Neutral (Phase)			
	⊕	Ground			
Parallel Operation with 9PX8000 UPS	L1	Phase	4-35 mm ² (12-4 AWG)	25 mm ² (2 AWG)	100A
	N (L2)	Neutral (Phase)			
	⊕	Ground			
Redundancy Only with 9PX11000 UPS	L1	Phase	4-35 mm ² (12-4 AWG)	10 mm ² (8 AWG)	63A
	N (L2)	Neutral (Phase)			
	⊕	Ground			
Redundancy Only with 9PX8000 UPS	L1	Phase	4-35 mm ² (12-4 AWG)	10 mm ² (8 AWG)	50A
	N (L2)	Neutral (Phase)			
	⊕	Ground			

4. Power cables connection



This type of connection must be carried out by qualified electrical personnel.

Before carrying out any connection, check that the upstream protection device (Normal AC source) is open "O" (Off).



Before proceeding to connect the ModularEasy to the UPS, make sure the UPS has been properly shut down (refer to the UPS user manual).

Always connect the ground wire first.

4.1 9PXMEZ6Ki

1. Connect the 2 power cables of I/O cord Set ① to the UPS I/O terminal blocks, following color coding on the cables and on the UPS I/O cover (blue for UPS Input / red for UPS Output) – refer to the UPS user manual to check the UPS terminal blocks connection
2. Connect the ModularEasy detection cable from the I/O cord Set ① to the specific UPS connector (MBP detect, refer to UPS User Manual "614-09200").

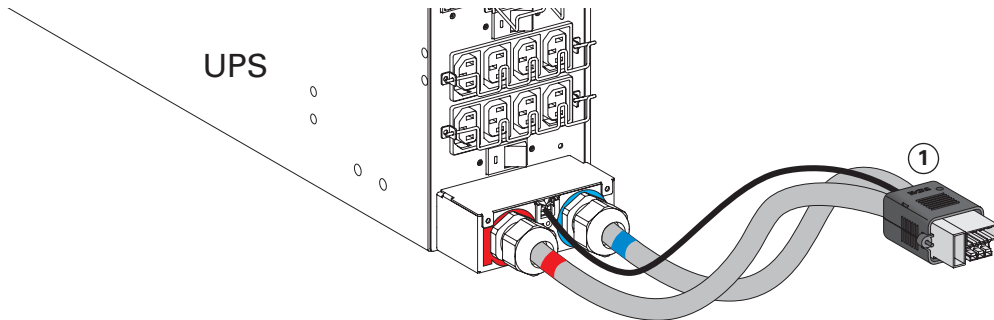

3. Slide the ModularEasy I/O cover ② after removing the screw, to access the ModularEasy terminal blocks

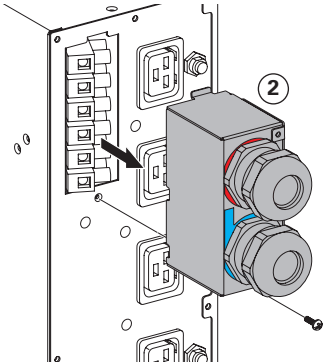

4. Insert the Normal AC source cable through the cable gland
5. Connect the wires to the Normal AC source (Input) terminal blocks
6. Insert the Output cable through the cable gland
7. Connect the wires to the Output terminal blocks

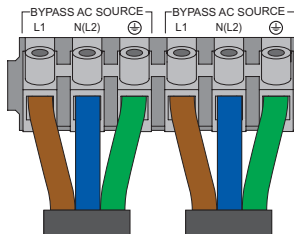

8. Tighten the cable glands
9. Slide back and secure the ModularEasy I/O cover ② with the screw

4. Power cables connection

10. Connect the I/O cord Set ① connector to the ModularEasy, and secure it by fixing the two locking screws

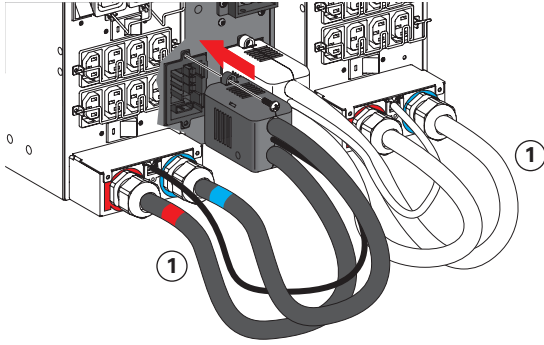

11. Connect the two UPS together with the 9PX parallel cable and lock it.



Use of specific parallel cable is mandatory for first start up and optimal use.

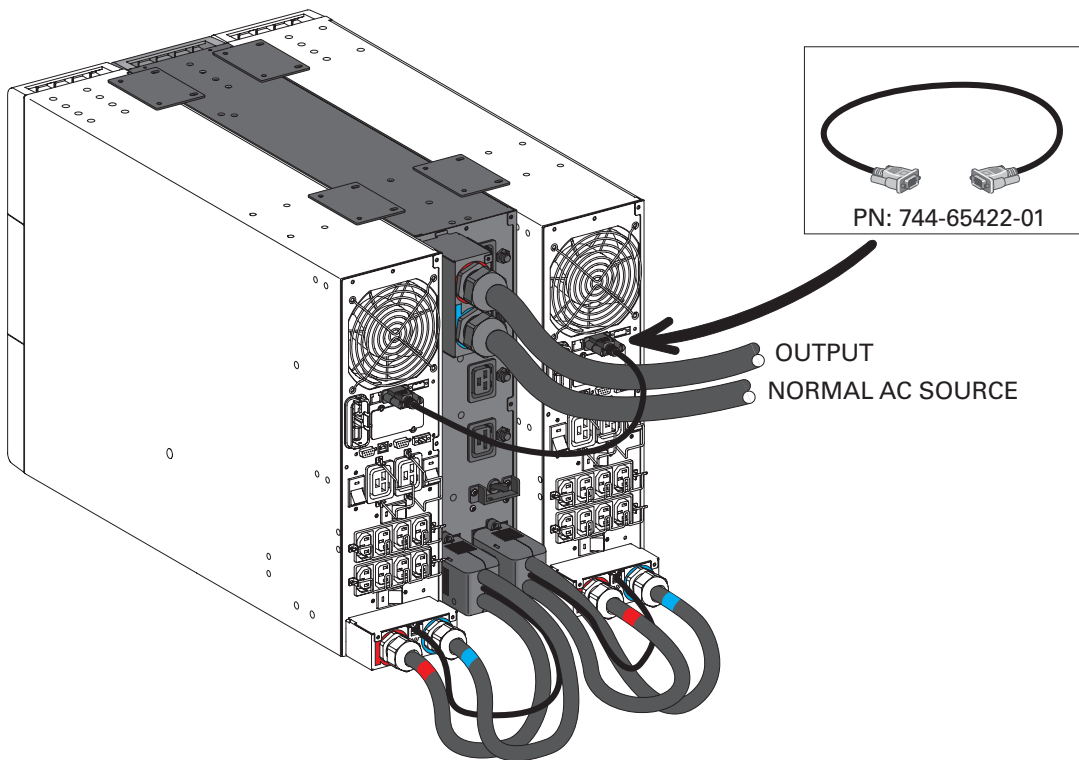

4. Power cables connection

4.2 9PXMEZ11Ki - with **common** Normal and Bypass AC source

1. Connect the 4 integrated power cables ① to UPS1 and UPS2 I/O terminal blocks, following color coding on the cables and on UPS I/O cover (blue for UPS Input / red for UPS Output) – do not remove the UPS Input Bypass AC jumper inside the UPS I/O cover - refer to the UPS user manual to check the UPS terminal blocks connection.
2. Connect ModularEasy detection cables ② to the specific UPS connector (MBP detect, refer to the UPS User Manual "614-09260").

Rack installation

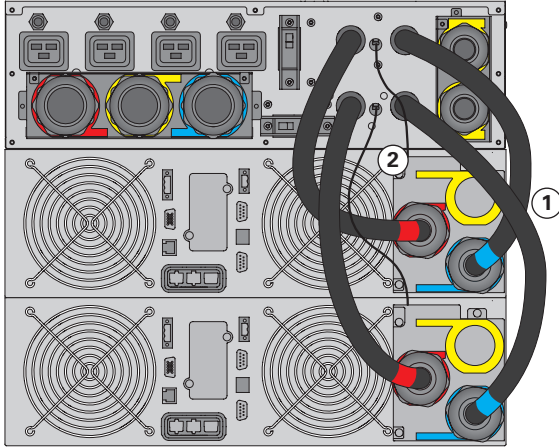

Tower installation

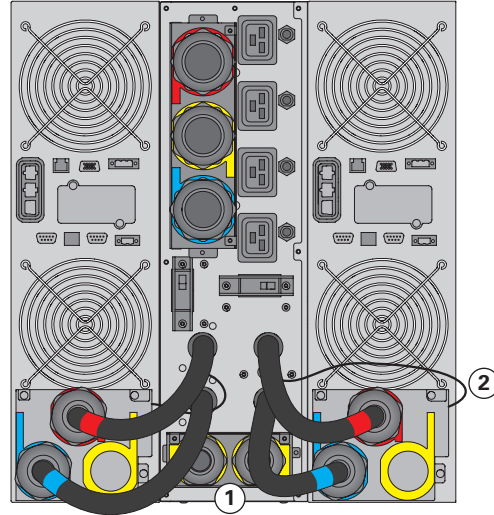

Do not increase or reduce the length of the integrated power cable.

3. Slide the ModularEasy I/O cover ③ after removing the 2 screws, to access the ModularEasy terminal blocks.

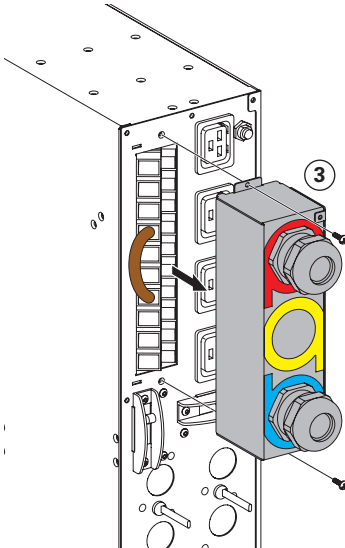

4. Power cables connection

4. Insert the Normal AC source cable through the cable gland.
5. Connect the wires to the Normal AC source (Input) terminal blocks (do not remove the Input Bypass AC jumper ④ and the UPS Input Bypass jumper inside the UPS I/O cover refer to the UPS User Manual)
6. Insert the Output cable through the cable gland.
7. Connect the wires to the Output terminal blocks.

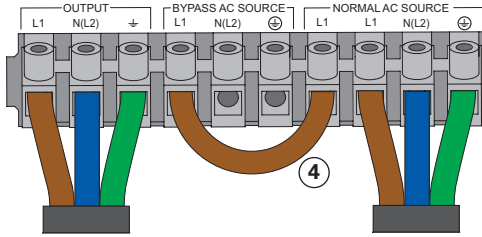

8. Tighten the cable glands.
9. Slide back and secure the ModularEasy I/O cover ③ with the 2 screws.
10. Check EBM connected to UPS.
11. Connect the two UPS together with the 9PX parallel cable and lock it.



Use of specific parallel cable is mandatory for first start up and optimal use.

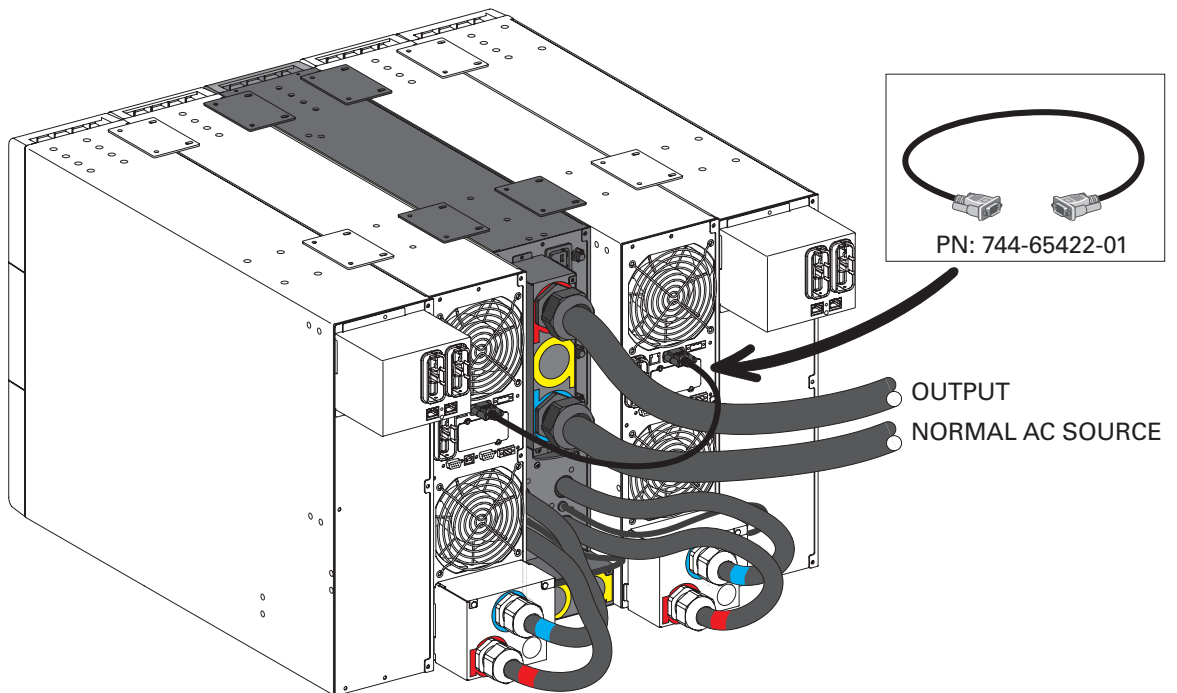

4. Power cables connection

4.3 9PXMEZ11Ki - with separate Normal and Bypass AC source

1. Slide the ModularEasy Bypass input cover ⑤ after removing the screw.
2. Punch the two Bypass Input knockouts of the ModularEasy Bypass Input cover ⑤ and insert the two small provided cable glands inside.

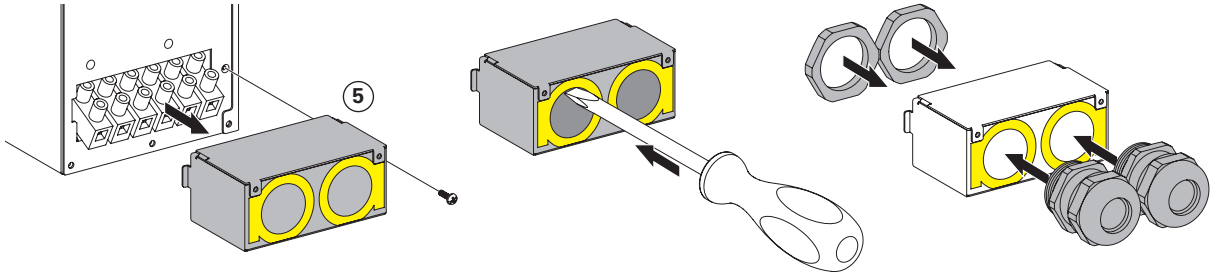

3. Insert a power cable through each cable glands of the ModularEasy Bypass Input cover ⑤. Cables are not provided in the packaging. It is recommended to use a cable with 3 conductors, 50 cm in length and with a minimum wire size rating : 10 mm² (8 AWG).

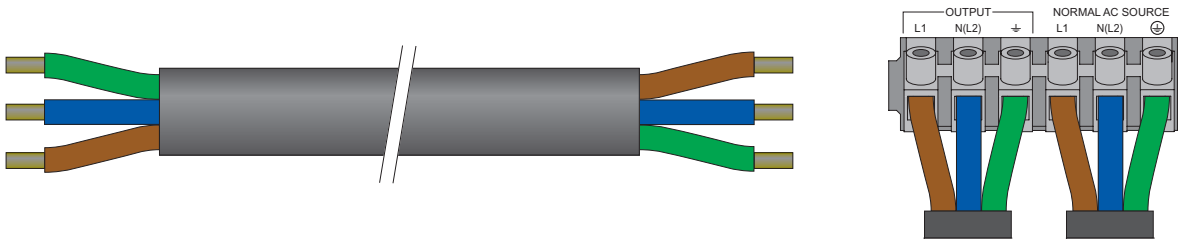

4. Connect the wires to the "Input BP" terminal blocks of the ModularEasy Bypass Input cover ⑤.
5. Tighten the cable gland.
6. Slide back and secure the ModularEasy Bypass Input cover ⑤ with the screw.

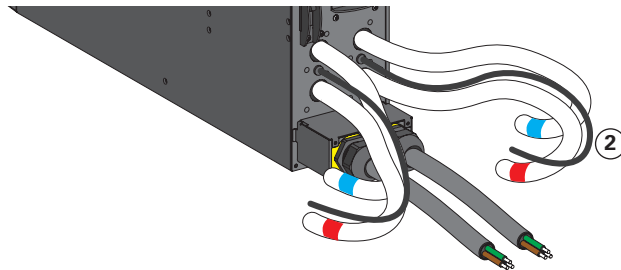

7. Connect the 4 integrated power cables and the 2 previously installed Bypass Input power cables to the UPS1 and UPS2 I/O terminal blocks.
Following color coding on the cables and the UPS I/O cover (blue for UPS Input / red for UPS Output / yellow for UPS Input Bypass) – refer to the UPS user manual to check the UPS terminal blocks connection. Do not forget to **remove the Input Bypass AC jumper on the UPS**.
8. Connect the ModularEasy detection cable ② to the specific UPS connector (refer to the UPS User Manual).
9. Slide the ModularEasy I/O cover ③ after removing the two screws, to access the ModularEasy terminal blocks.

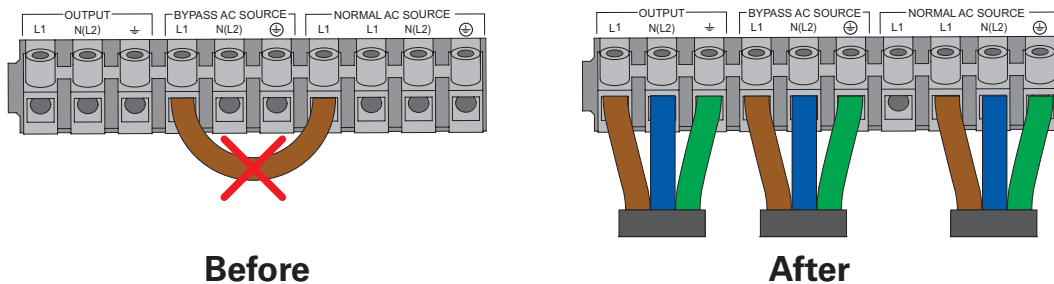

4. Power cables connection

- 10. Remove the Input Bypass AC jumper (4).
- 11. Punch the Bypass AC Source knockout of the ModularEasy I/O cover (3) and insert the bigger provided cable gland inside.

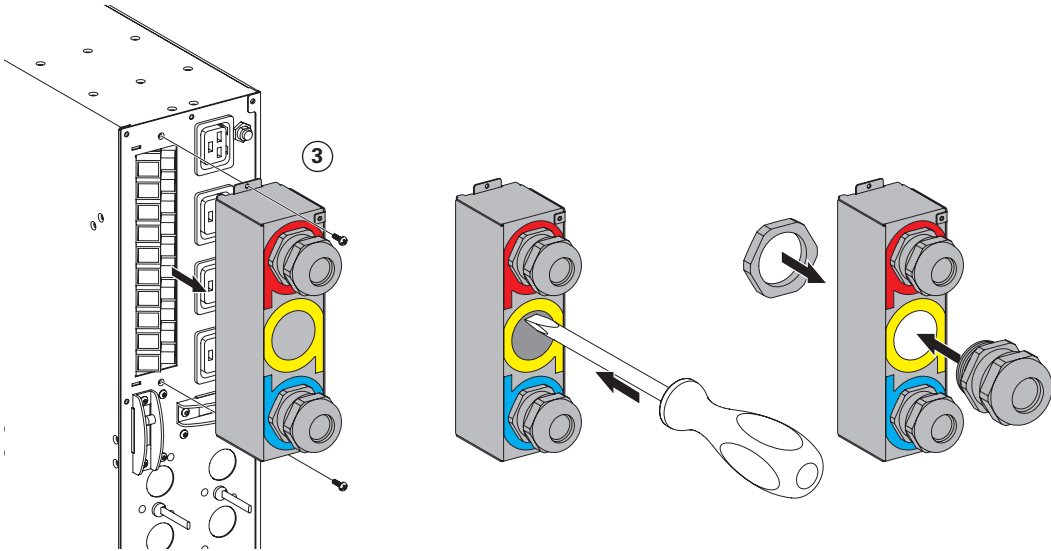

- 12. Insert the Normal AC source cable through the cable gland.
- 13. Connect the wires to the Normal AC source (Input) terminal blocks.
- 14. Insert the Bypass AC source cable through the cable gland.
- 15. Connect the wires to the Bypass AC source (Input BP) terminal blocks.
- 16. Insert the Output cable through the cable gland.
- 17. Connect the wires to the Output terminal blocks.
- 18. Tighten the cable glands.
- 19. Slide back and secure the ModularEasy I/O cover (3) with the two screws.
- 20. Check EBM connected to UPS.
- 21. Connect the two UPS together with the 9PX parallel cable and lock it.



Use of specific parallel cable is mandatory for first start up and optimal use.

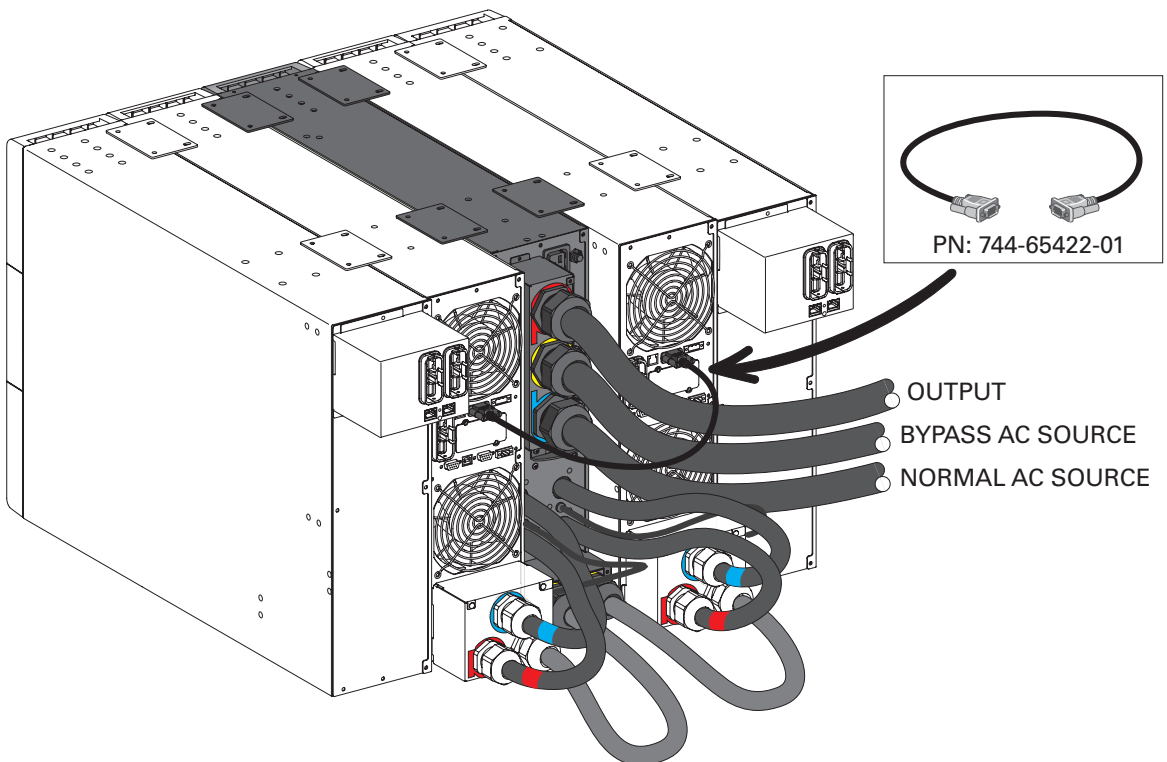

5. Operations

5.1 UPS parallel system start-up



In "Redundancy Only" mode, verify that the total equipment ratings do not exceed the capacity of one UPS to prevent an overload alarm.
In "Parallel Operation" mode, verify that the total equipment ratings do not exceed the capacity of two UPS to prevent an overload alarm.

1. Check the two UPS are correctly connected to the ModularEasy (see "4. Power cables connection", page 14).

If the UPS is equipped with outlets, those outlets can no longer be used (loads can only be connected to the ModularEasy outlets or the ModularEasy Output terminal blocks)



Check that two UPS are connected together with the 9PX parallel cable.

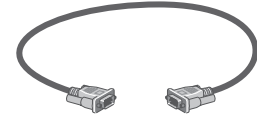

PN: 744-65422-01

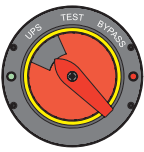

2. Check that the ModularEasy terminal blocks are connected to the AC source, and to the Bypass AC source (*)
3. Check that the ModularEasy manual Bypass switch is to the "UPS" position
4. Set the UPS output switch of the ModularEasy to the "I" position (On) for 9PXMEZ6Ki.
Set the two UPS output switches of the ModularEasy to the "I" position (On) for 9PXMEZ11Ki
5. Set the AC source upstream circuit breaker (not provided) to the "I" position (On) to switch on the utility power (see "3.5 9PXMEZ11Ki SETUP", page 10).
Set the Bypass source upstream circuit breaker (not provided) to the "I" position (On) to switch on the Bypass power (*).
6. Check that the two UPS are correctly powered (UPS display panel lighted)
7. Check the two UPS display "**1 UPS + 1 UPS redundant**". Do not continue to the next step if it is not displayed and check the two following features :

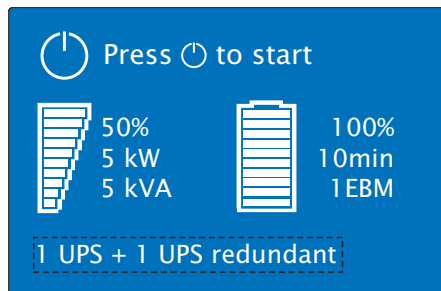

- a) The two UPS are connected together with the parallel cable, PN: 744-65422-01
- b) The UPS firmware version is parallel compatible :

Screen menu → Identification → UPS/NMC firmware.

If "/// Ready" doesn't appear just next to the UPS firmware number, contact your Eaton reseller to download the latest firmware.

8. Choose the mode "**Redundancy Only**" or "**Parallel Operation**" by the Screen menu → Settings → In/Out settings → Redundancy mode.
 - "**Parallel Operation**" is the default mode. "Parallel Operation" cancels the audible alarm when the load power is more than the maximum power of one UPS.
 - "**Redundancy Only**" set an audible alarm when the load power is more than the maximum power of one UPS .
9. Press the "**ON**" button of any one of the two UPS to start the parallel system.

(*) **only in case of Bypass AC source option connected (9PXMEZ11Ki only).**

5.2 UPS maintenance with ModularEasy

UPS Maintenance:

1. Put the two UPS in "**internal Bypass mode**" (refer to the UPS user manual)
2. Check that the two UPS are on Bypass mode by checking the UPS display panel (refer to the UPS user manual)
3. Set the ModularEasy manual bypass switch to "Test" position. The "Bypass" red light of the ModularEasy goes On, indicating that the load is supplied directly by AC source, or optional Bypass AC source on 9PXMEZ11Ki
4. To test UPS in unitary, switch the UPS output switch of the ModularEasy to the "0" position (OFF)
To test the two UPS in parallel, let the UPS output switch of the ModularEasy to the "1" position (ON)
5. Proceed to maintenance operations on UPS (refer to the UPS User Manual).

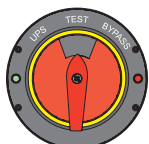

Return to normal operation:

1. - **9PXMEZ6Ki**: check the "UPS output" switch of the ModularEasy is to the "I" position (On).
- **9PXMEZ11Ki**: check the two "UPS output" switches of the ModularEasy are to the "I" position (On).
2. Check that the UPS is on Bypass mode by checking the UPS display panel (refer to the UPS user manual)



3. Check the 9PX parallel cable are correctly connected and fixed.

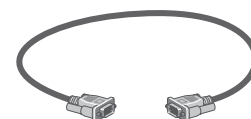

PN: 744-65422-01

4. Check the two UPS display "**1 UPS + 1 UPS redundant**". Do not continue to the next step if it is not displayed and check the two following features :

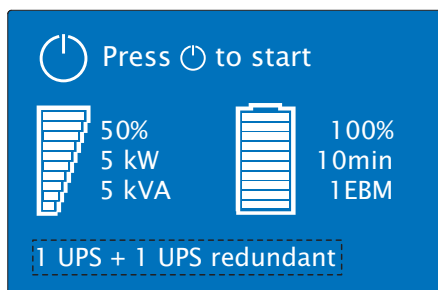

- a) The two UPS are connected together with the parallel cable, PN: 744-65422-01
- b) The UPS firmware version is parallel compatible :
Screen menu → Identification → UPS/NMC firmware.
If "**// Ready**" doesn't appear just next to the UPS firmware number, contact your Eaton reseller to download the latest firmware.

5. Check that the "**UPS mode**" **green light** of the ModularEasy is on, indicating that the UPS output power is available on the ModularEasy



Important: do not continue to next step if the "**UPS mode**" **green light** of the ModularEasy is off (the load will be lost).

6. Set the ModularEasy manual Bypass switch to the "**UPS**" position: the "**Bypass mode**" **red light** of the ModularEasy goes off, indicating that the load is now powered by the UPS
7. Put the UPS in "**Online**" mode (refer to the UPS User Manual)
8. Check that the UPS is in Online mode by checking the UPS display panel (refer to the UPS user manual).

The load is now protected by the UPS.

5. Operations

5.3 UPS replacement with ModularEasy

5.3.1 Faulty UPS Removing:



1. Put the UPS in "internal Bypass mode" (refer to the UPS user manual)
2. Check that the UPS is on Bypass mode by checking the UPS display panel (refer to the UPS user manual)
3. Set the ModularEasy manual Bypass switch to "Bypass" position.
The "Bypass mode" red light of the ModularEasy goes on, indicating that the load is supplied directly by AC source, or by optional Bypass AC source on 9PXMEZ11Ki only
4. Wait until the UPS turns off in around 30 seconds
5. Check that the UPS display is off. If the display is still lighted, check the UPS "Sleep mode" by referring to the UPS user manual. Do not continue to the next step if display is still lighted
6. Set the UPS output switch of the ModularEasy to the "0" position (OFF) for 9PXMEZ6Ki or, set the two UPS output switches of the ModularEasy to the "0" position (OFF) for 9PXMEZ11Ki
7. Disconnect all internal (*) and external batteries of the faulty UPS.
(*) only for UPS 9PX5000 and 9PX6000.
8. Check if all of the power supply is really disconnected by pressing the ON/OFF button  of the faulty UPS for 5 seconds.
The UPS must stay off.
9. Check that the UPS display is still off.



Important: Do not continue to the next step if display is lighted.

Now UPS can be disconnected, as described below:

5.3.2 9PXMEZ6Ki

- First disconnect the I/O cord Set ① of the faulty UPS from the ModularEasy, after removing the two screws

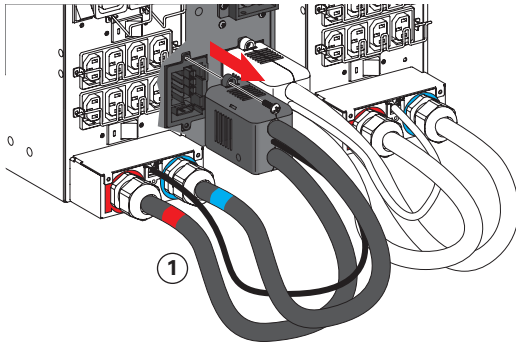

- After opening the UPS I/O terminal blocks cover of the faulty UPS, check if hazardous voltage is no longer present on UPS terminal blocks by using an electrical safety tester

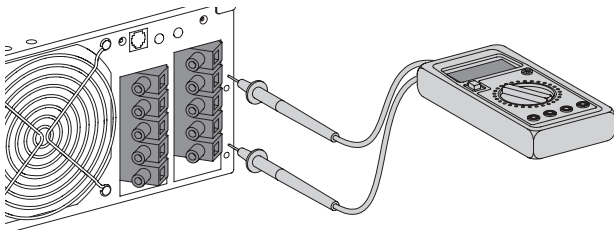

- Disconnect the I/O cord Set ① and connect it to a new UPS
- Reconnect the I/O cord Set ① from the new UPS to the ModularEasy



Hazardous voltage and lost load risk: do not manipulate the ModularEasy manual Bypass switch unless the I/O cord Set ① is connected to UPS terminal blocks.

5.3 UPS replacement with ModularEasy

5.3.3 9PXMEZ11Ki

- After opening the UPS I/O terminal blocks cover of the faulty UPS, check if hazardous voltage is no longer present on UPS terminal blocks by using an electrical safety tester

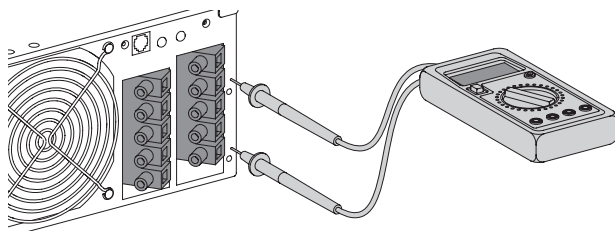

- Disconnect the ModularEasy power cables, and the ModularEasy detection cable of the faulty UPS
- Reconnect immediately the ModularEasy power cables, and the ModularEasy detection cable to a new UPS. If it is not possible to reconnect the ModularEasy power cables immediately, link their 3 wires together (line and neutral wires connected to ground wire) to prevent an electrical shock and reconnect them to a new UPS later.



Hazardous voltage and lost load risk: do not manipulate the ModularEasy manual bypass switch unless the ModularEasy power cables are connected to UPS terminal blocks.

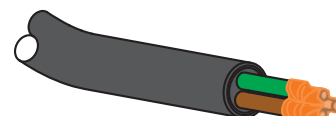

5.3.4 Return to normal operation:

- Check that the new UPS is correctly connected to the ModularEasy, see 4.1, 4.2, 4.3
- For 9PXMEZ6Ki, check the "UPS output" switch of the ModularEasy is to the "I" position (On).
For 9PXMEZ11Ki, check the two "UPS output" switches of the ModularEasy are to the "I" position (On)
- Check the 9PX parallel cable is correctly connected and fixed (PN: 744-65422-01).
- Set the ModularEasy manual bypass switch to **"Test" position**.
- Verify that the UPS is correctly powered (UPS display panel is lighted)
- Check the two UPS display **"1 UPS + 1 UPS redundant"**.
Do not continue to the next step if it is not displayed and check the two following features :

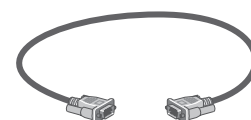

PN: 744-65422-01

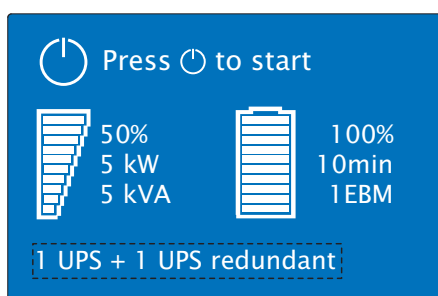
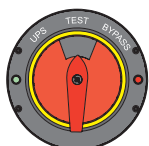

- The two UPS are connected together with the parallel cable, PN: 744-65422-01
 - The UPS firmware version is parallel compatible :
Screen menu → Identification → UPS/NMC firmware.
If **"// Ready"** doesn't appear just next to the UPS firmware number, contact your Eaton reseller to download the latest firmware.
- Press the **"ON"** button of any one of the 2 UPS to start the parallel system.
 - Put the UPS in **"internal Bypass mode"** (refer to the UPS User Manual)
 - Verify that the UPS is on Bypass mode by checking UPS display panel (refer to the UPS user manual)
 - Verify that the **"UPS mode" green light** of the ModularEasy goes On, indicating that the UPS output power is available on the ModularEasy

Important: do not continue to next step if the **"UPS mode" green light** of the ModularEasy is still Off (the load will be lost).

- Set the ModularEasy manual Bypass switch to the **"UPS"** position. The **"Bypass mode" red light** of the ModularEasy turns Off, indicating that the load is now powered by the UPS
- Put the UPS in **"Online mode"** (refer to the UPS User Manual)
- Check that the UPS is in Online mode by checking the UPS display panel (refer to the UPS user manual)

The load is now protected by the UPS.

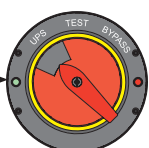

6. Troubleshooting

Condition	Possible cause	Action
One UPS displays: Load unbalance	One of the "UPS output" switches is off on the back of the ModularEasy	Switch on the "UPS output" switch on the ModularEasy
Firmware download is not possible	One of the two UPS is in Online or Battery mode	Select Standby or Bypass mode

7. Specifications

	9PXMEZ6Ki	9PXMEZ11Ki
Input Bypass		
	N/A	Terminal blocks
Output		
	4 IEC 16A + Terminal blocks	4 IEC 16A + Terminal blocks
Overall dimensions D x W x H (inch / mm)		
	27 x 17 x 5 / 690 x 440 x 130	
Weight (lb / kg)		
	22.8 / 10.3	32.6 / 15
Performance		
Nominal voltage	200 - 240 V ~	200 - 250 V ~
Frequency	50/60 Hz	
Input nominal current	60A	100A
Maximal power	12000 VA	22000 VA
Standards		
Safety	IEC/EN 62040-1 / Ed.1: 2008	
EMC	IEC/EN 62040-2 / Ed.2: 2006	
Performance	IEC/EN 62040-3 / Ed.2.0: 2011	
ESD	IEC 61000-4-2 : level 3.	
Radiated field	IEC 61000-4-3 : level 3.	
EFT	IEC 61000-4-4 : level 4.	
Fast transients	IEC 61000-4-5 : level 4.	
Electromagnetic field	IEC 61000-4-6 : level 3.	
Conducted magnetic field	IEC 61000-4-8 : level 4.	
Marking		
	CE	
Environment		
Operating temperature	0 to 40°C (32 to 104°F)	
Storage temperature	-15 to 60°C (5 to 140°F)	
Transit temperature	-25 to 55°C (-13 to 130°F)	
Humidity	0 to 95% no condensing	
Operation Altitude	Up to 3,000 meters (9,843 ft) above sea level with 10% derating per 1000m	
Transit Altitude	Up to 10,000 meters (32,808 ft) above sea level	